

# GSX-7A

## Two Pad SM Crystal with Ceramic Package

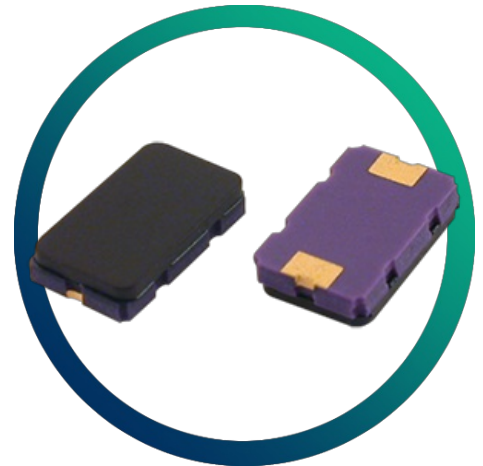

- Fundamental mode available up to 40.0MHz
- Low cost for volume applications

### CONFIGURABLE OPTIONS

| Parameter                | Option Code |
|--------------------------|-------------|
| Frequency                |             |
| Overall stability        |             |
| ±100ppm incl cal tol     |             |
| Circuit condition        |             |
| Any                      |             |
| 16pF (fund)              |             |
| Series resonant (3rd OT) |             |

### SPECIFICATIONS

|                                      |  |
|--------------------------------------|--|
| Frequency range                      | 12.0 ~ 40.0MHz (fund)<br>40.0 ~ 67.0MHz (3rd OT)   |
| Dimensions                           | 6.2 x 3.7 x 1.4mm  |
| Operating temperature range          | -10 to +60°C   |
| Storage temperature range            | -30 to +85°C   |
| Static capacitance (C <sub>0</sub> ) | 7pF max  |
| Equivalent series resistance         | 60Ω max (12.0 ~ <16.0MHz)<br>40Ω max (16.0 ~ 40.0MHz)<br>70Ω max (>40.0 ~ 67.0MHz, 3rd OT) |
| Ageing                               | ±5ppm max first year   |
| Test drive level                     | 100μW  |
| Soldering condition                  | 260°C, 10 sec x2 max   |
| Net mass                             | 72.0mg   |

### PACKAGE DRAWING

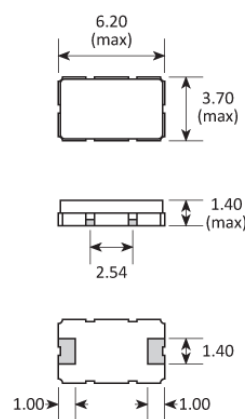

### SOLDER PAD LAYOUT

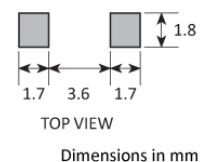

## ORDERING INFORMATION

To request a quotation for the GSX-7A please use the configurable options form to choose the options you require and then submit your configured product to our team. Our expert advisers are always happy to help with your requirements and can be contacted on +44 1460 256 100 or at [sales@golledge.com](mailto:sales@golledge.com).

Following product selection you will be issued with a seven character Golledge part number. Your Golledge part number is the internationally accepted Golledge manufacturing part number (MPN) that should be used for all project documentation, including bills of materials (BoMs) and purchase orders.

If you have any queries regarding any of our documentation our dedicated sales team will be happy to help.

## TAPE & REEL SPECIFICATION

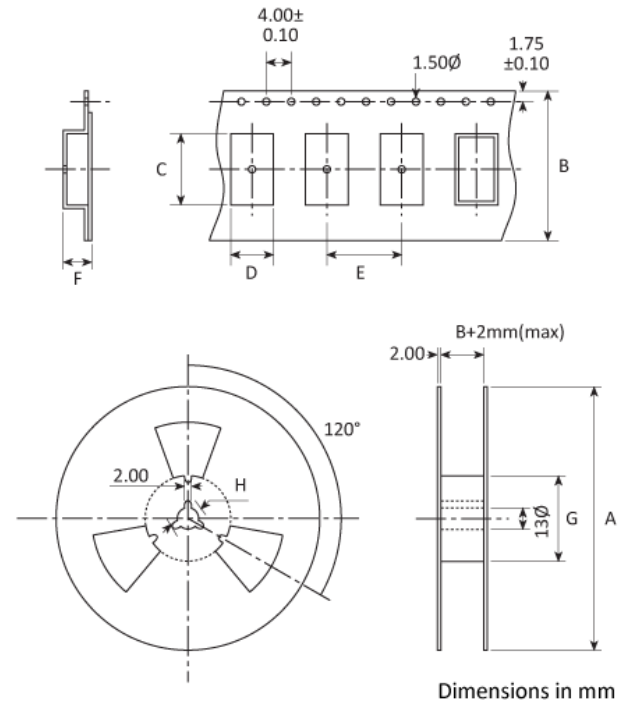

A:178\* B:12 C:6.4 D:3.9 E:8 F:1.9 G:80 H:21

\*Larger reel size available. Please ask for details

## HANDLING & STORAGE



Human Body Model (HBM) 1A (250V to <500V)



Moisture Sensitivity Level (MSL): 1 (or not applicable)

## CONSTRUCTION

Ceramic base and lid

## COMPLIANCE

---

Please refer to our **DOCUMENTS** section for more information.



Lead-free (< 0.1% by weight)



RoHS compliant with no exemptions.



REACH compliant.



Free of conflict minerals.



Free from halogens.



Free from ozone-depleting substances.