

Product Description

Description:	12.2880MHz GSX-333/P21PF SM Crystal
Product family:	GSX-333
Category:	SM Quartz Crystal
Order code:	MP05808

Features

- ▶ Metal lid can be grounded to minimise EMI
- ▶ Seam sealed for excellent long-term stability
- ▶ Ultra-miniature for maximum space saving

Additional Information

For further information regarding packaging, construction, material composition, soldering profile and environment, please refer to **GSX-333 Product Information sheet**

For dimensions, refer to package drawing: **D0262-A**

Electrical Specifications

Parameter	Value	Notes
Nominal frequency:	12.2880MHz	
Calibration tolerance:	±15ppm max	At 25°C ±3°C
Temperature stability:	±20ppm max	Referred to frequency at 25°C
Operating temperature range:	-10 to +60°C	
Storage temperature range:	-40 to +85°C	
Circuit condition:	15pF	
Static capacitance (C ₀):	3.0pF max	
Oscillation mode:	Fundamental	
Equivalent series resistance:	100Ω max	
Aging:	±1ppm/year max	
Test drive level:	10μW typ	100μW max

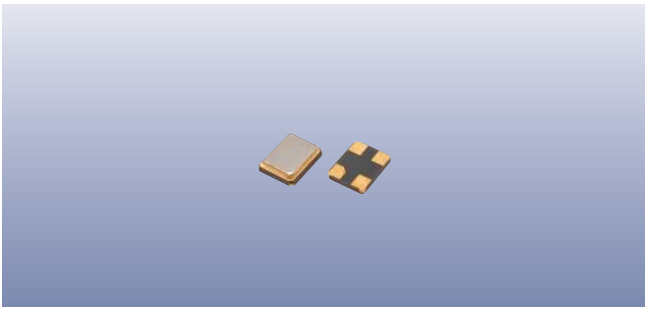

Construction

- ▮ Ceramic body with gold-plated pads
- ▮ Metal lid, seam sealed

Composition



This product is lead-free, and is fully compliant with the RoHS directive 2002/95/EC



Packaging & Handling

Production quantities supplied on T&R, 3k pcs per reel.
Small quantities may be supplied on tape (no reel), or in bulk.

Marking

FREQUENCY
T zDC

Marking type: Laser
DC = Date code in YW, as shown below
Example: "zd" = 2012 week 30

Year	2009	2010	2011	2012
	2013	2014	2015	2016
Code	Z	z	z̄	z̅

Week codes:

A ~ Z: weeks 1 to 26
a ~ z: weeks 27 to 52

Tape & Reel Specification

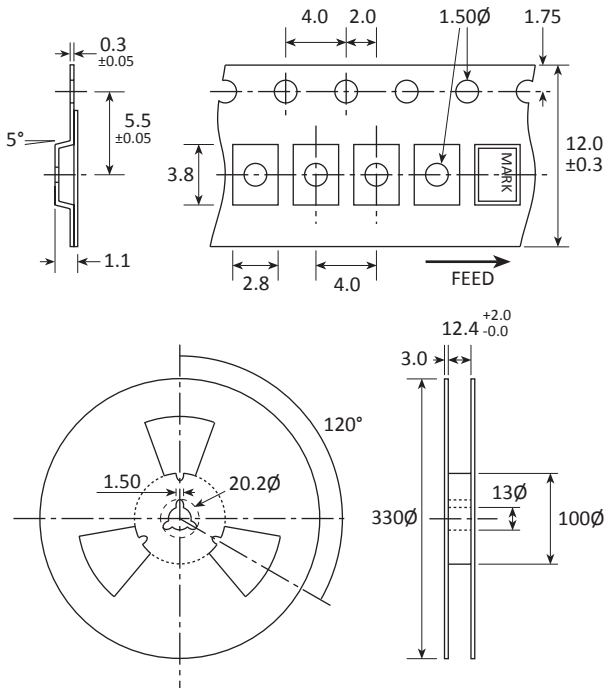

Not to scale. Dimensional tolerances ±0.1mm unless otherwise stated.

Soldering Profile

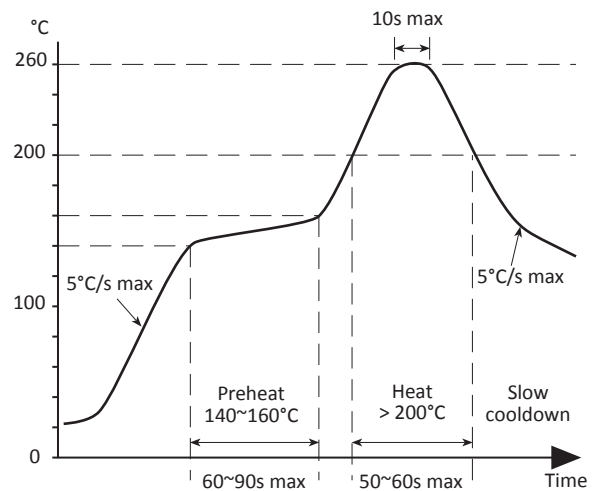

Maximum solder resistance: 260°C x 10 secs x 2.

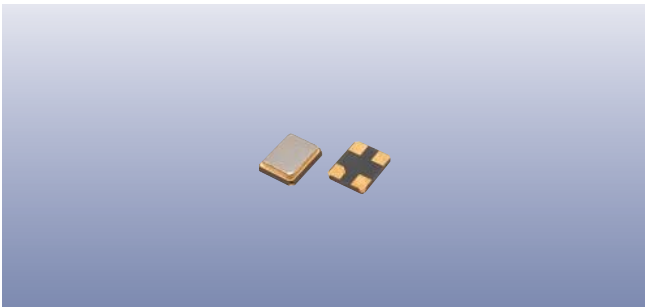

Product Family

GSX-333

Construction

- ▣▣▣▣ Ceramic body with gold-plated pads
- ▣▣▣▣ Metal lid, seam sealed

Dimensions (mm)

