

Product Description

Description:	24.0MHz GSX-333/124EF SM Crystal
Product family:	GSX-333
Category:	SM Quartz Crystal
Order code:	MP04672

Features

- ▶▶▶ Metal lid can be grounded to minimise EMI
- ▶▶▶ Seam sealed for excellent long-term stability
- ▶▶▶ Ultra-miniature for maximum space saving

Additional Information

For further information regarding packaging, construction, material composition, soldering profile and environment, please refer to **GSX-333 Product Information sheet**

For dimensions, refer to package drawing: **D0262-A**

Electrical Specifications

Parameter	Value	Notes
Nominal frequency:	24.0MHz	
Calibration tolerance:	±10ppm max	@25°C ±3°C
Temperature stability:	±20ppm max	Referred to frequency @25°C
Operating temperature range:	-40 to +85°C	
Storage temperature range:	-40 to +85°C	
Circuit condition (C _L):	18pF	
Oscillation mode:	Fundamental	
Equivalent series resistance:	50Ω max	
Frequency perturbation:	±1ppm max	
Ageing:	±1ppm max	First year
Test drive level:	10μW	

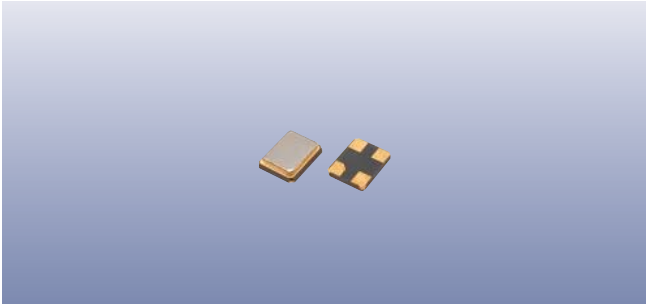

Packaging & Handling

Production quantities supplied on T&R, 3k pcs per reel.
Small quantities may be supplied on tape (no reel), or in bulk.

Marking

FREQUENCY
T DC

Marking type: Laser
DC = Date code

Tape & Reel Specification

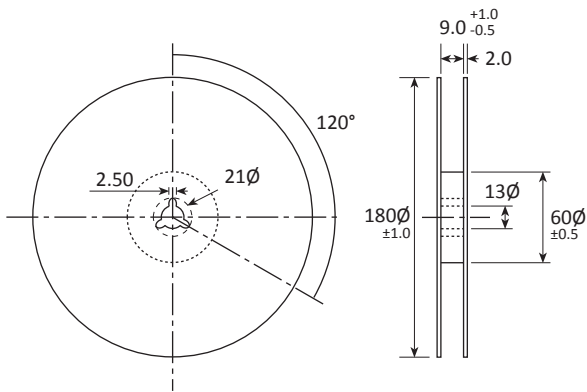
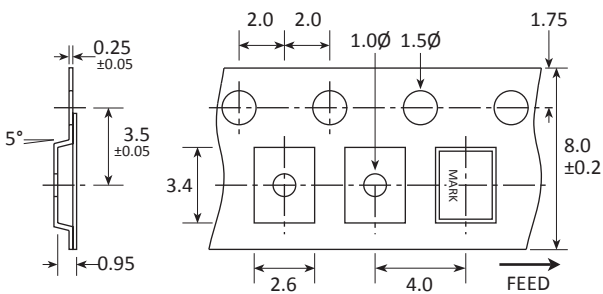

Not to scale. Dimensional tolerances ±0.1mm unless otherwise stated.

Construction

- ▮ Ceramic body with gold-plated pads
- ▮ Metal lid, seam sealed

Composition



This product is lead-free, and is fully compliant with current RoHS directives



Soldering Profile

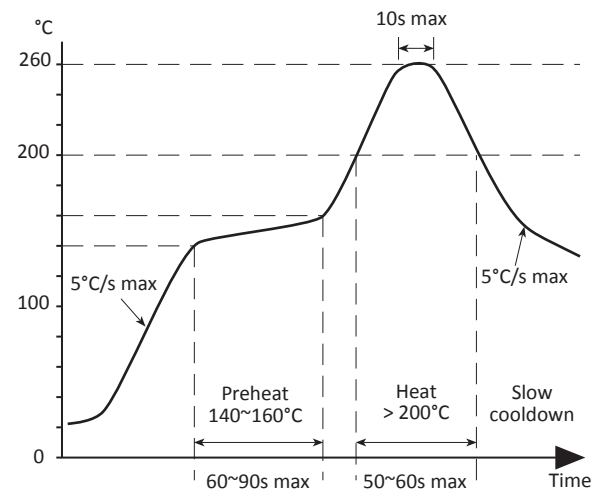

Maximum solder resistance: 260°C x 10 secs x 2.

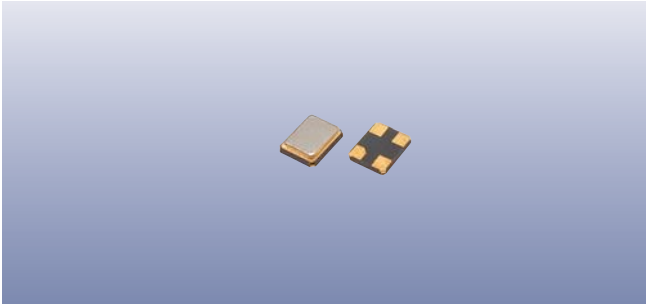

Product Family

GSX-333

Construction

- ▮▮▮▮ Ceramic body with gold-plated pads
- ▮▮▮▮ Metal lid, seam sealed

Dimensions (mm)

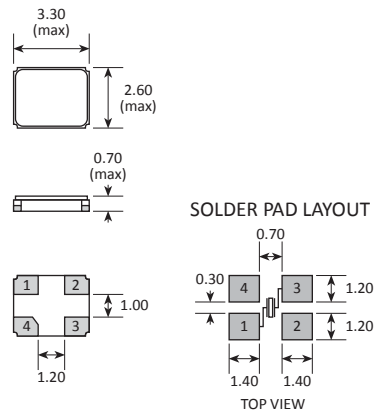

PAD	CONNECTION
1	Crystal
2	Ground & lid
3	Crystal
4	Ground & lid

NOTE: Chamfer normally on pad 4, but may alternatively be supplied on pad 1.