

**SAW Filter 153.60MHz**  
**Part No: MP03477**

**Model: TB0772A**  
**Rev No: 1**

**A. MAXIMUM RATING:**

1. Operating Temperature: -0°C ~ +70°C
2. Storage Temperature: -40°C ~ +85°C
3. Input power: 10dBm

**B. CHARACTERISTICS:**

Ambient Temperature: 25°C

Characteristics	Value			Note
	Min.	Typ.	Max.	
Center frequency Fc MHz	-	153.6	-	-
Minimum Insertion loss IL dB	-	9.5	13.0	-
1dB BW MHz	20	23.18	-	-
Passband Ripple (Fc ± 10.0MHz) dB	-	0.45	1.0	-
Attenuation (Reference to Minimum Insertion loss)				
139.6MHz dB	10	19.5	-	-
168.6MHz dB	10	26	-	-
Temp Coefficient ppm/K	-	-94	-	-
Matching:  1. The input of the filter will be matched to 50Ω  2. The output of the filter will be matched to 50Ω				

**SAW Filter 153.60MHz**  
**Part No: MP03477**

**Model: TB0772A**  
**Rev No: 1**

**C. FREQUENCY CHARACTERISTICS:**

1. S21 Response: (span: 80MHz)

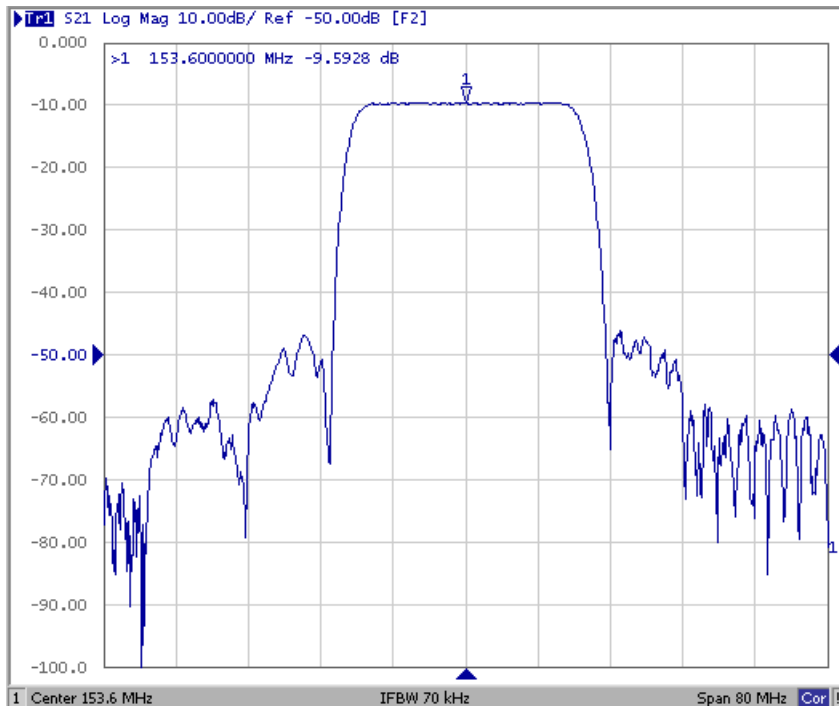

Fig. 1. Horizontal: 8MHz/Div, Vertical: 10dB/Div

2. Group-Delay Ripple: (span: 40MHz)

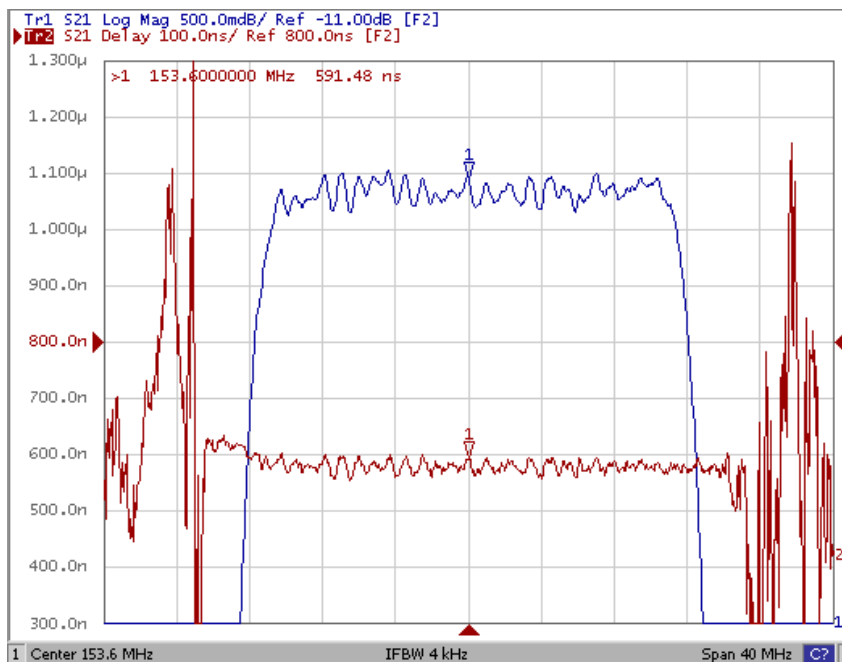
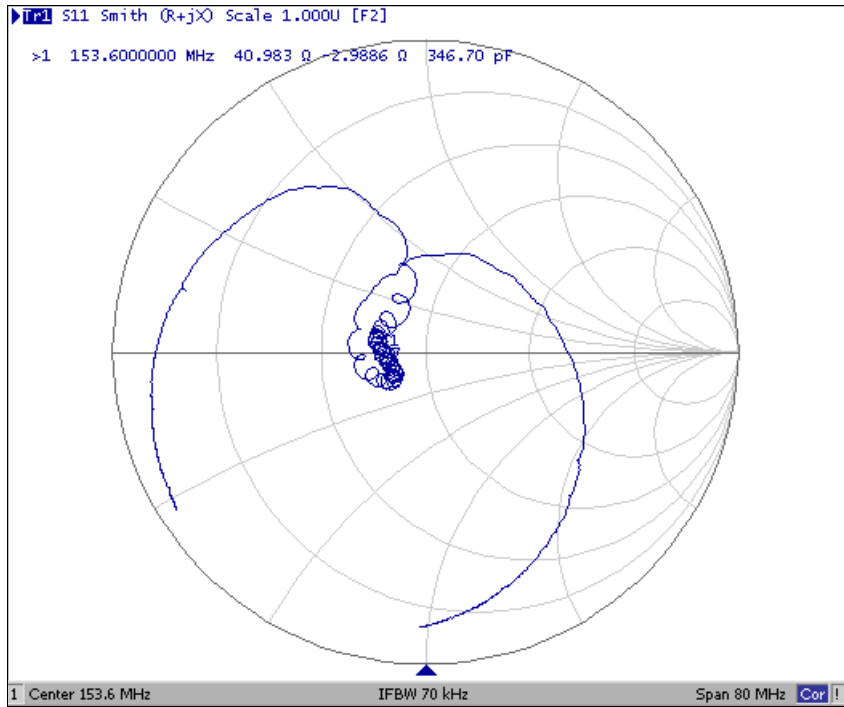

Fig. 2. Horizontal: 4MHz/Div, Vertical: 100nec/Div

**SAW Filter 153.60MHz**  
**Part No: MP03477**

**Model: TB0772A**  
**Rev No: 1**

3. S11 Smith Chart: (span: 80MHz)



4. S22 Smith Chart (span: 80MHz)

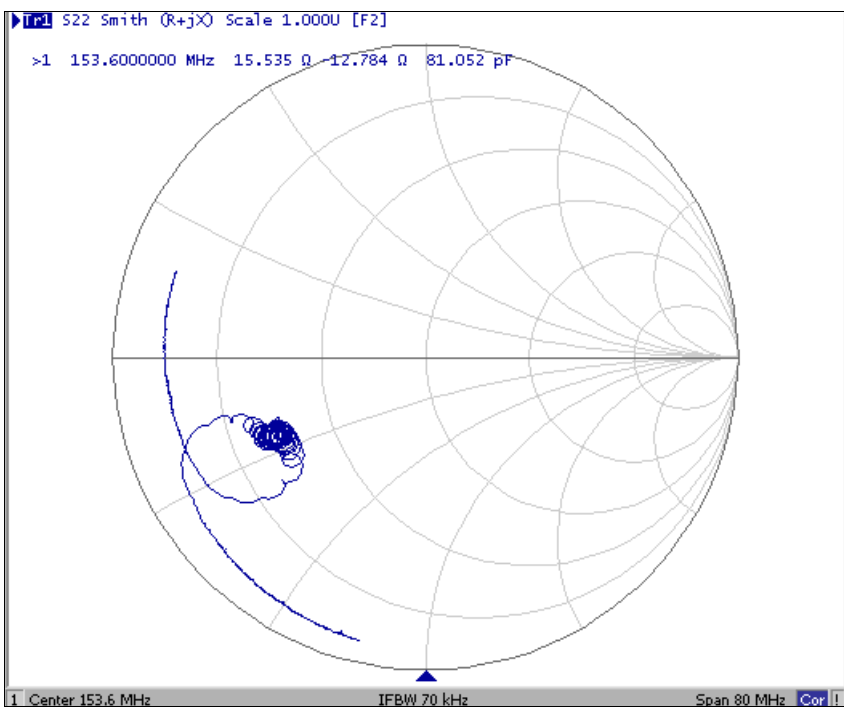

**SAW Filter 153.60MHz**  
**Part No: MP03477**

**Model: TB0772A**  
**Rev No: 1**

**D. MEASUREMENT CIRCUIT:**

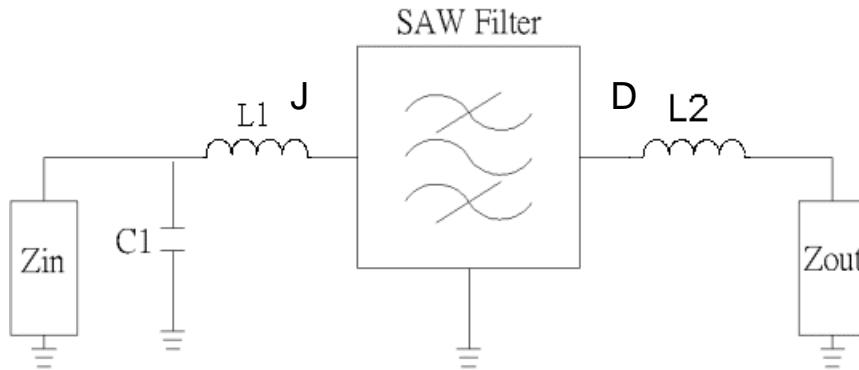

$Z_{in}$  and  $Z_{out}$  are  $50\ \Omega$ .  
 $L1=82\text{nH}$ ,  $C1=27\text{pF}$ ,  $L2=33\text{nH}$

**E. OUTLINE DRAWING:**

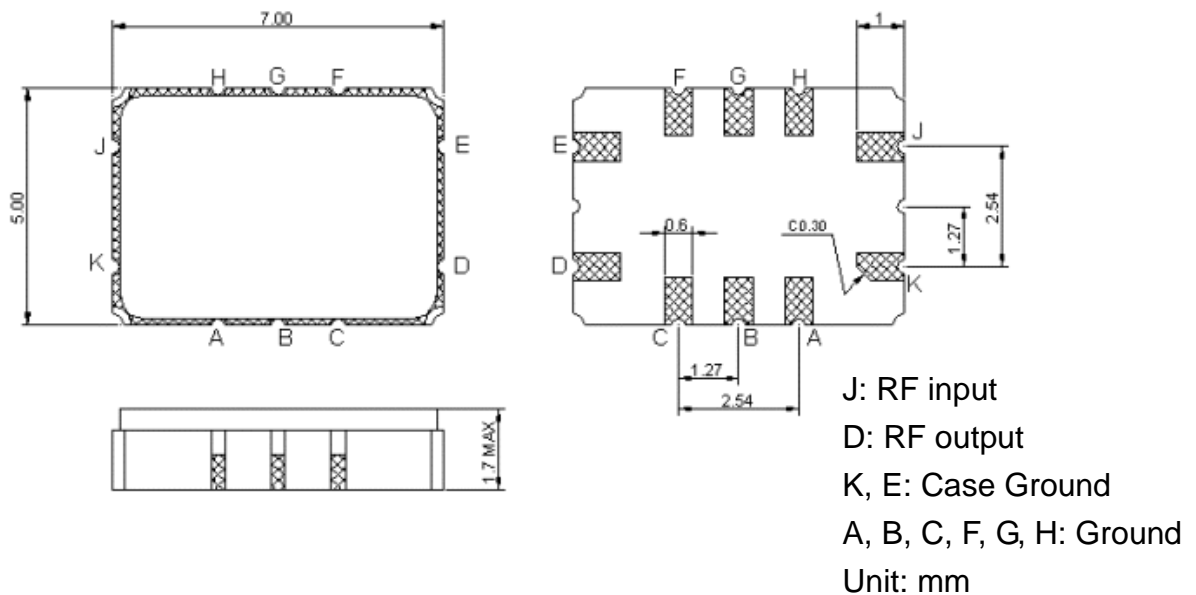

**F. PCB FOOTPRINT:**

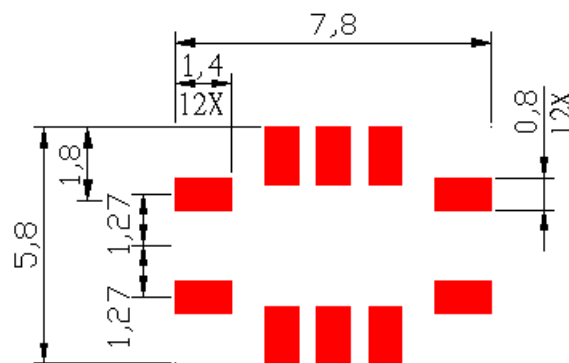

**SAW Filter 153.60MHz**  
**Part No: MP03477**

**Model: TB0772A**  
**Rev No: 1**

**G. PACKING:**

**1. REEL DIMENSION**

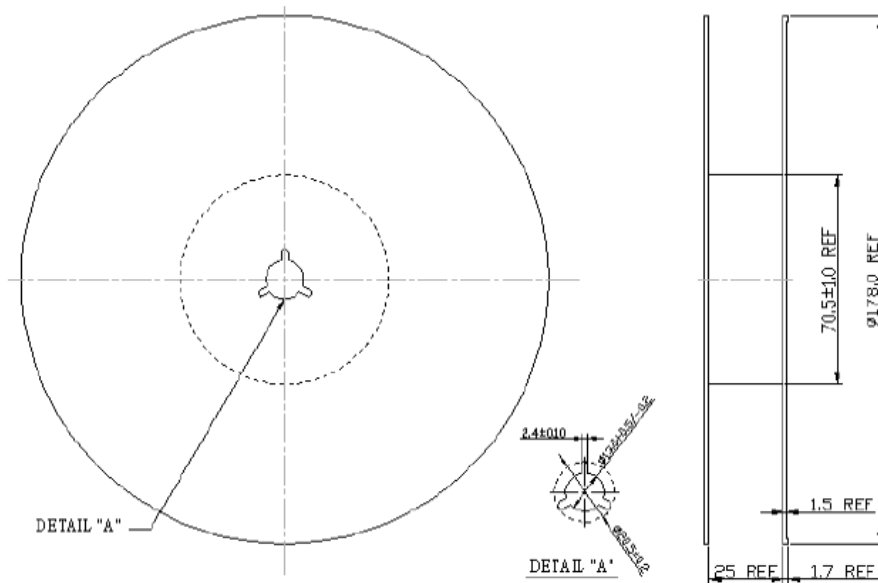

**2. TAPE DIMENSION**

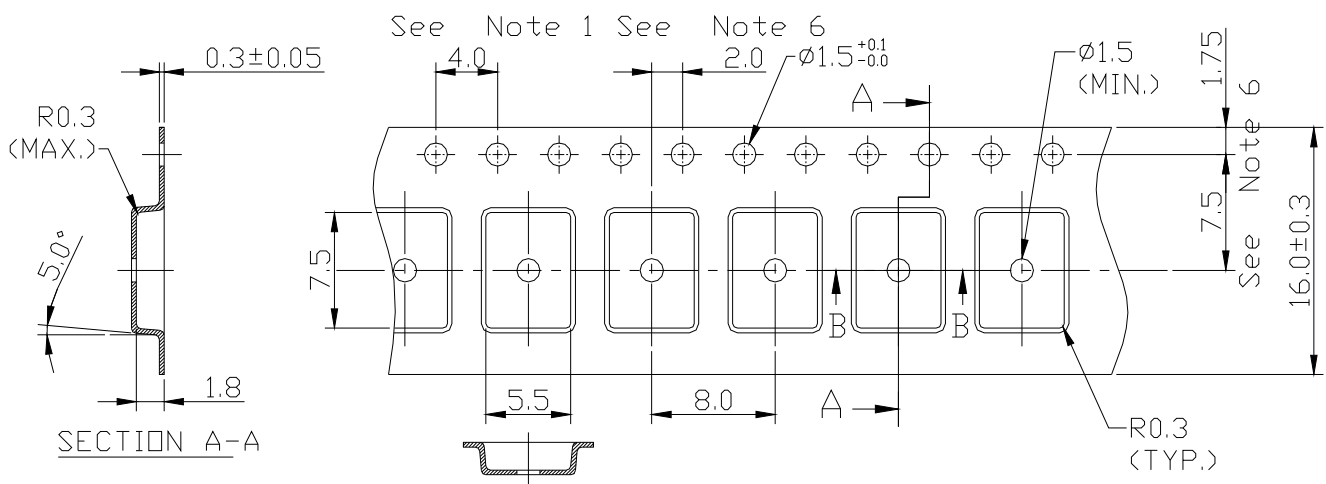

**SAW Filter 153.60MHz**  
**Part No: MP03477**

**Model: TB0772A**  
**Rev No: 1**

**H. RECOMMENDED REFLOW PROFILE:**

